



AXISENSE-G DUAL AXIS GYRO STABILIZED TILT SENSOR

SPECIFICATIONS

- $\pm 75^\circ$ Dual Axis Tilt Sensor
- Gyro Stabilized for Fast Response
- CAN J1939 Interface
- Packaged for Harsh Environments
- Inherent Shock Suppression
- Simple Mounting Features

FEATURES

- Multi-axis Gyro and Accelerometer
- Sensitive to Pitch and Roll Movements
- Factory Calibrated and Compensated
- Built-in Diagnostics
- -40 to 85 °C Operating Temperature
- Survives 10,000 g Shock Events
- Cable with 4-pin Superseal™ Connector

APPLICATIONS

- Stationary and Mobile Cranes and Hoists
- Forklifts and Material Handling Equipment
- Dump Trucks
- Vehicle Chassis Levelling
- Excavation Equipment
- Agricultural Machines
- Road Paving Equipment
- Scissor and Man Lifts

The Model AXISENSE-G is a dual axis tilt sensor that combines signals from a multi-axis accelerometer and multi-axis gyro into an accurate representation of pitch and roll angles. The addition of the gyro improves the reaction time of the sensor and reduces susceptibility to shock and vibration events.

The sensor uses gravity for the reference and reports any positive or negative tilt angle in both the X and Y axes. The static accuracy for these measurements is $\pm 0.5^\circ$.

The tilt sensor is packaged in a rugged enclosure with simple mounting features. It's designed to be immune to harsh environments commonly found in automotive and off-road vehicle applications. The IP67 rating makes the sensor suitable for use outdoors.

The sensor is supplied with a 400 mm (15.7") integrated cable and a 4-pin sealed, keyed, latching connector. The wide supply voltage range of 8 – 36 VDC allows the sensor to operate with most electrical systems. A built-in temperature sensor and self-diagnostic features immediately notify the user or system of any problems or malfunctions.

AXISENSE-G DUAL AXIS GYRO STABILIZED TILT SENSOR

ABSOLUTE MAXIMUM RATINGS ^{a)}

Parameter	Symbol	Min	Typ	Max	Unit	Notes/Conditions
Supply voltage	V _{CC}	-40		40	V	Reference to GND
Operating/storage temperature	T _{STO}	-40		85	°C	
Operating humidity	H _{OP}			100	%RH	>80% <40% of time
Storage humidity	H _{STO}			60	%RH	Unpowered
Shock limit (any axis)	a _{shock}			10,000	g	Non-repetitive 0.2 ms
Mounting screw torque	M _{fix}		10	15	Nm	M6 size
Cable bend radius		24			mm	Static Installation Dynamic Installation
		48				

a) Maximum limits the device will withstand without damage.

ELECTRICAL SPECIFICATIONS

(Unless otherwise specified, all parameters are measured at 23 °C @ 12 V applied)

Parameters	Symbol	Min	Typ	Max	Unit	Notes/Conditions
Supply voltage	V _{CC}	8	12	36	Vdc	
Supply current	I _{CC1}	15	20	45	mA	
CAN speed	f _{CAN}		250		kbps	
CAN transmission rate ¹⁾		5		100	ms	Configurable ⁴⁾

1) Limited by CAN protocol.

OPERATING SPECIFICATIONS

(Unless otherwise specified, all parameters are measured at 23 °C @ 12 V applied)

Parameter	Symbol	Min	Typ	Max	Unit	Notes/Conditions
Measurement range		-75		+75	deg	X & Y axes, ref to gravity
Installation offset	Δ _{OFF}			±0.3	deg	
Absolute Accuracy, x/roll angle ^{2) 7)}	Δ _{STAT,x}		±0.50	±1.50	deg	Static Depends on actual tilt angles, see Figure 1 for details.
Absolute Accuracy, y/pitch angle ²⁾	Δ _{STAT,y}			±0.5	deg	Static Whole angular range
Mean Accuracy, RMS ⁶⁾	Δ _{DYN}		±1.5		deg	Dynamic Whole angular range
Predicted Lifetime Stability	Δ _{LT}			±0.5	deg	
Settling time ³⁾	t _{SET}		300		ms	90% of final reading
Resolution ¹⁾	RES			0.01	deg	
Orientation Algorithm Update rate ⁵⁾	f _u		100		Hz	
Startup time	t _s			1.0	s	V _{CC} 0 to 24V transition

2) Absolute accuracy is the worst-case deviation between output angle and actual angle. Static accuracy is verified by an end of line measurement at different angles after calibration. The sensor module will not be removed from fixture in between. Static implies no movement of the sensor. As the inclinometer is designed to be fixed with M6 screws, there is some mechanical clearance that may lead to a small misalignment and offset in application. For some applications, it may be reasonable to implement an in-application offset correction to attain best overall accuracy.

3) Depends on filter setting.

4) Configurable from 5 ms to 100 ms, see notes on page 10.

5) Gyroscope and accelerometer are sampled at 1 kHz. Signals are carefully filtered and sampled down to 100 Hz

6) Dynamic accuracy is the RMS (root mean square) deviation between output angle and set angle, tested under three different conditions:

- linear acceleration in one sensor axis with 0.3 g for a period of 1 second or
- random vibration with 0.3 g RMS or
- rotational movement of one sensor axis with a rotational velocity of 30 °/s

It is important to note that this error depends very much on the desired application and the strength of vibration and additional acceleration. Testing the sensor in the application is recommended.

7) Due to mathematical properties of the roll/x angle sensor output, the absolute static error depends on the actual pitch/y angle for y values > 50°. See Figure 1 for details.

AXISENSE-G DUAL AXIS GYRO STABILIZED TILT SENSOR

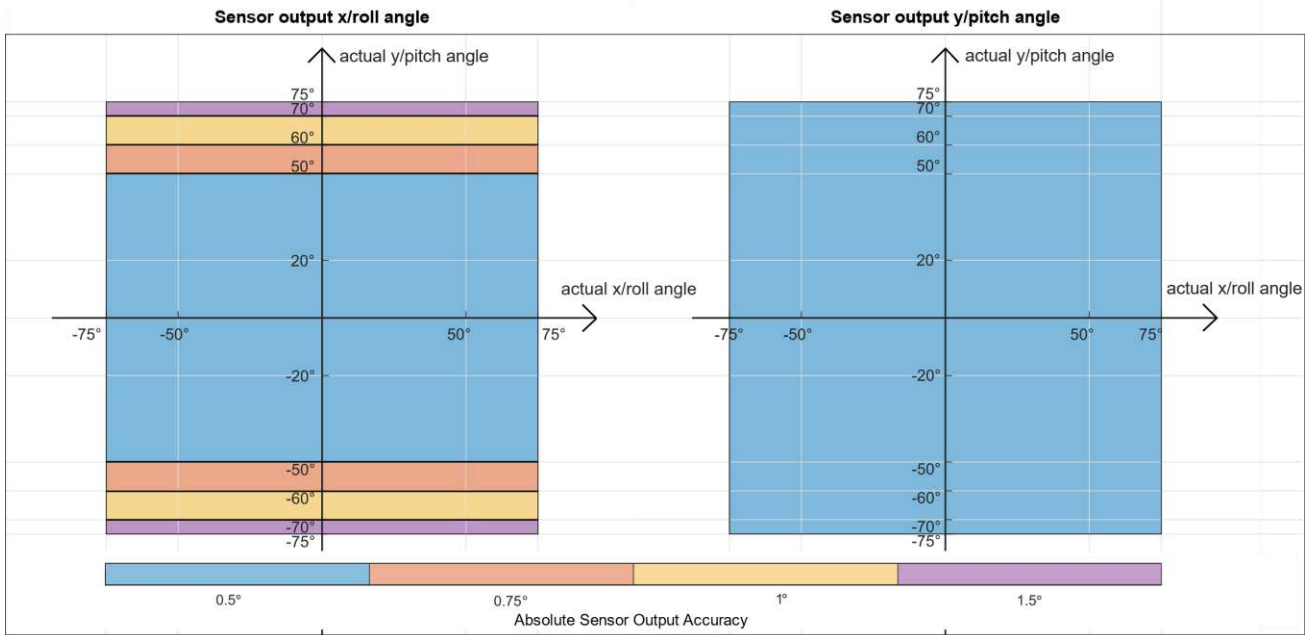

Figure 1: Definition of the absolute sensor output accuracy across the whole measurement range of $\pm 75^\circ$. Left: Sensor output x/roll angle. Interval-wise accuracy definition related to the actual y/pitch angle. Right: Sensor output y/pitch angle, constant accuracy throughout the whole measurement range.

ENVIRONMENTAL SPECIFICATIONS

Parameter	Symbol	Min	Typ	Max	Unit	Notes/Conditions
Operating temperature		-40		85	°C	
Storage temperature		-40		85	°C	
Operating ambient humidity		0		60	%RH	>80% <40% of time
Ingress protection	IP67					
Media compatibility		External exposed surfaces: Nylon, Polyurethane Resin, Brass, Polyamid				
Compliance		RoHS 2 directive 2011/65/EU REACH 1907/2006				
Weight			60		grams	

AXISENSE-G DUAL AXIS GYRO STABILIZED TILT SENSOR

FUNCTIONAL OPERATION

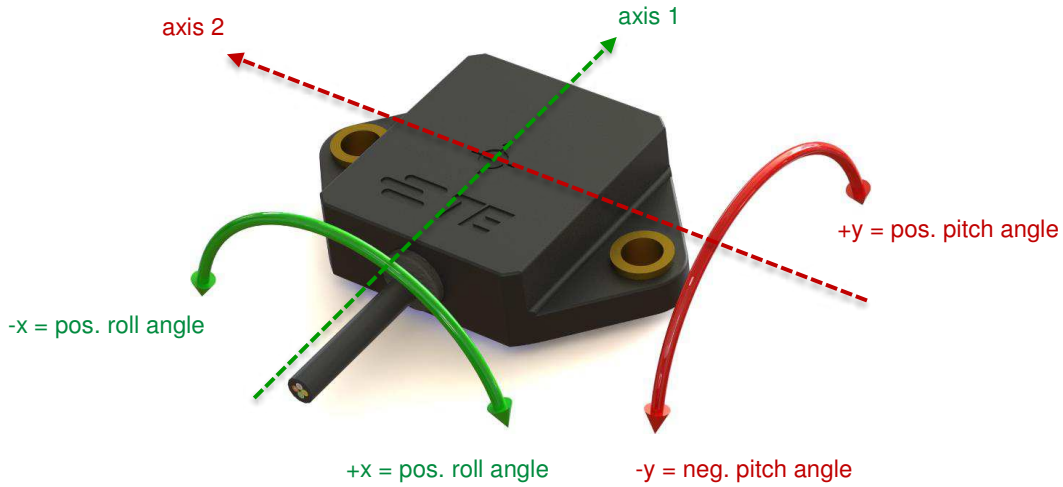

Figure 2: Sensitive Axes Orientation

Angles are defined according to **DIN 70000** and **ISO 8855**:

- Roll measures rotation angle *around* the (local) body x-axis
- Pitch measures rotation angle *around* the (local) body y-axis

BLOCK DIAGRAM

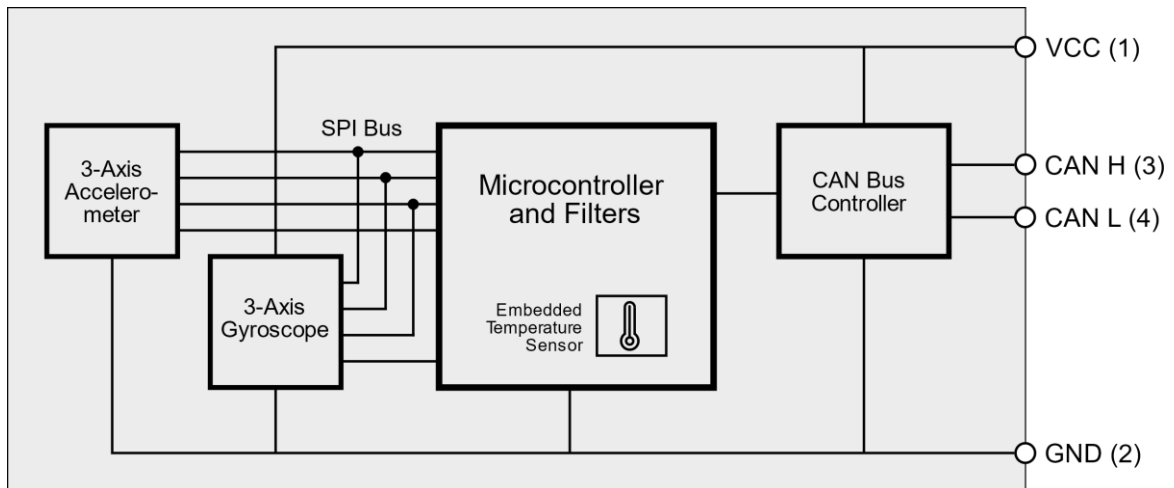

Figure 3: Block Diagram

AXISENSE-G DUAL AXIS GYRO STABILIZED TILT SENSOR

OUTLINE DIMENSIONS

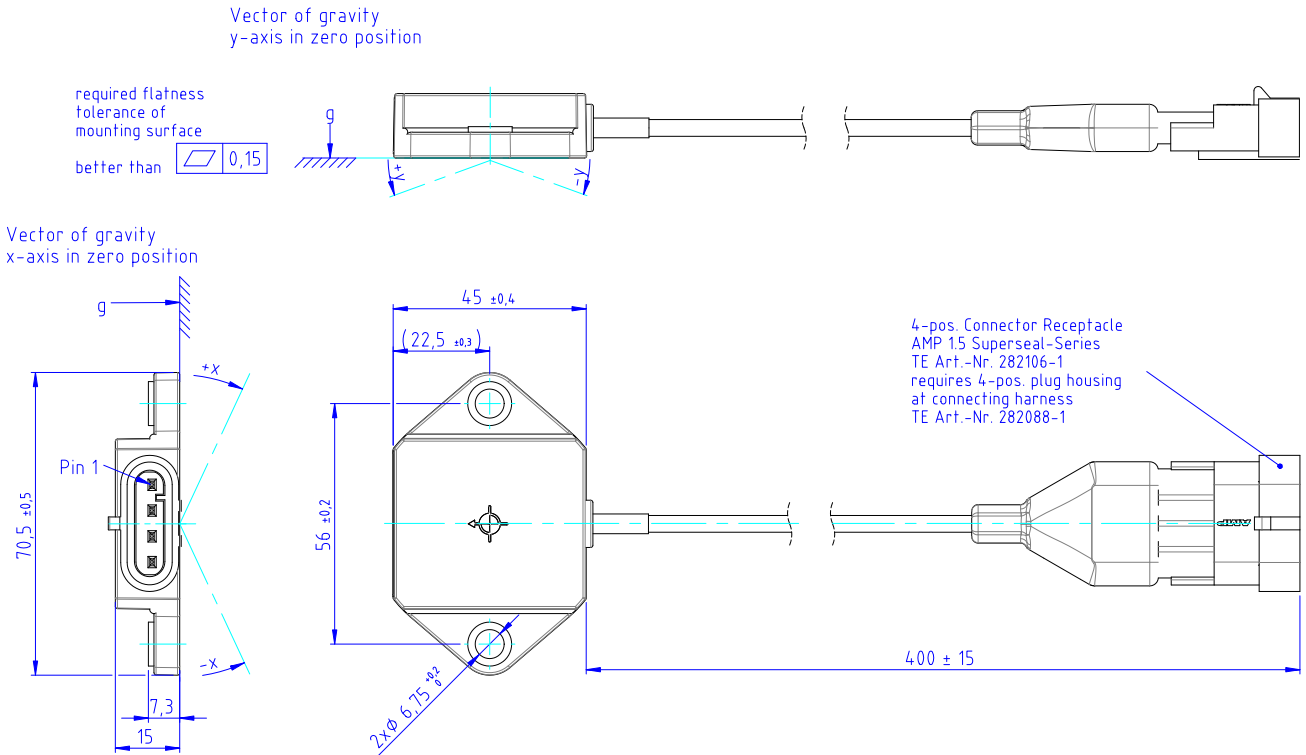

Figure 4: Dimensions

CONNECTOR DETAIL

The tilt sensor has an AMP Superseal series connector with 4 terminals (TE Connectivity part-no. 282106-1). It mates with TE Connectivity part-no. 282088-1.

Pin Number	Function	Description	Wire Color	Direction
1	Supply voltage - V _{CC}	8 – 36 V	White	Input
2	Ground - GND	0V	Yellow	Input
3	CAN_H	CAN high line	Brown	Input/output
4	CAN_L	CAN low line	Green	Input/output

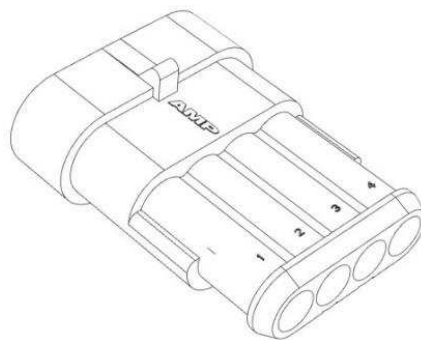

Figure 5: Connector Pinout

AXISENSE-G DUAL AXIS GYRO STABILIZED TILT SENSOR

ELECTRICAL INTERFACE

The tilt sensor has a SAE J1939 CAN-compatible interface described in detail in the following section. OEM adaptation is possible.

Conventions

The tilt sensor complies with SAE J1939 CAN2.0B and uses a baud rate of 250 kbps. Proprietary A (0xEF) and B (0xFF) portions of SAE J1939 are used. The 29-bit message identifiers can be formulated using the following scheme:

Bit Position	Description
28:26	Message priority (6 is lowest, 0 is highest)
25:24	Future J1939 use. Always 0
23:16	Data content (PF). Always set to 0xFF for priority B
15:8	Data content (PS). (0x52 = Sensor serial number, 0x53 = Sensor Data, 0x54 = Ground Control Command to the sensor)
7:0	Source address (SA). Indicates which device sent the message (0xC0 = SA unassigned, 0x80 – 0xF7 = Chassis Tilt Sensor)

Source Addresses

The tilt sensor sends a onetime address claim message 500 ms after startup and upon request by the host:

Module	Source Address
Master (MA)	Various (except tilt sensor source address)
Tilt sensor (SA)	Uninitialized 0xC0 Settable range 0x80...0xF7

Description of Operation:

The tilt sensor broadcasts this message per J1939-81, 4.2.2.1 with byte definitions as follows:

Data Definition

Data Byte 0	Serial Number, Bits 0 - 7
Data Byte 1	Serial Number, Bits 8 - 15
Data Byte 2, Bits 0-4	Serial Number, Bits 16 - 20
Data Byte 2, Bits 5-7	Manufacturer Code, Bits 0 - 2
Data Byte 3	Manufacturer Code, Bits 3 - 10
Data Byte 4, Bits 0-2	ECU Instance = 0
Data Byte 4, Bits 3-7	Function Instance = 0
Data Byte 5	Function = 136 (Slope Sensor)
Data Byte 6, Bit 0	Reserved = 0
Data Byte 6, Bits 1-7	Vehicle System = 0 (Non-Specific System)
Data Byte 7, Bits 0-3	Vehicle System Instance = 0
Data Byte 7, Bits 4-6	Industry Group = 3 (Construction equipment)
Data Byte 7, Bit 7	Arbitrary Address Claim = 0 (Not Arbitrary)

Tilt Sensor Address Claim Request

Priority:	6	Source Address:	Master
Data Content (PF):	0xEA		
Data Content (PS):	Tilt Sensor	Repetition Rate:	On Request
Data	Byte	Function	
00	0	PGN (LSB)	
EA	1	PGN	
X	2	PGN (MSB)	

Description of Operation:

The tilt sensor broadcasts the “Tilt Sensor Address Claim” message upon receiving this message per J1939-21, 5.4.2 with byte definitions as follows:

Data Definition

Data Byte 0	PGN – Requestor Source Address
Data Byte 1	PGN (PF) – 0xEA (Address Claim)
Data Byte 2	PGN (PS) – 0xXX (Source Address of the Tilt Sensor)

Master Control Commands – Chassis Tilt Sensor

Priority:	4	Source Address:	Master
Data Content (PF):	0xFF (Proprietary B)	CAN ID	0x10FF54XX XX = Source Address of Master
Data Content (PS):	0x54	Repetition Rate:	On request

Data Byte	Function
0	Command Byte
1	Depends on Command Byte, see explanation below
2	Depends on Command Byte, see explanation below
3	Depends on Command Byte, see explanation below
4	Depends on Command Byte, see explanation below
5	Depends on Command Byte, see explanation below
6	Depends on Command Byte, see explanation below
7	Depends on Command Byte, see explanation below

Description of Operation

The master shall request the unique serial number (S.N.) of the Tilt Sensor. The intent is to assign different source addresses to the Chassis Tilt Sensor so that multiple sensors can operate on one CAN Bus. The first byte is the Command Byte specifying the meaning for the rest of the message. The rest of the data depends on the Command Byte as detailed below.

Request for Sensor S.N.

Data Byte	0	0x00 (commands sensor to respond with Sensor Serial Number message)
Data Bytes	1-7	0xFF; not used

Request for Source Address Change

Data Byte	0	0x01 (commands sensor with specified S.N. to change SA to given value; stored in the sensor non-volatile memory)
Data Byte	1	New Source Address in hexadecimal
Data Bytes	2-7	Not used

Request for Wait

Data Byte	0	0x02 (Stop all sensor responses and broadcast. This includes no response to a subsequent request for serial number commands or address claim)
Data Bytes	1-7	Not used

Request for Repetitive Transmission of Data

Data Byte	0	0x03 (Start sensor data broadcast and enable answering to requests)
Data Bytes	1-7	Not used

AXISENSE-G DUAL AXIS GYRO STABILIZED TILT SENSOR

Request for Transmission Rate Change

Data Byte	0	0x04 (changes the CAN broadcast transmission rate)
Data Byte	1	New transmission period in hex, see Table 1 for possible options
Data Bytes	2-7	Serial Number in BCD of target sensor

Table 2: Transmission rate options

Options	Resulting transmission rate
0x05	5 ms
0x0A	10 ms (default)
0x0F	15 ms
0x14	20 ms
0x3C	60 ms

Request for Return to Uninitialized Source Address

Data Byte	0	0x09 (commands sensor with specified SA and S.N. to change its SA currently stored in the sensor non-volatile memory to the uninitialized SA = 0xC0)
Data Byte	1	Current Source Address in hexadecimal of target sensor
Data Bytes	2-7	Serial Number in BCD of target sensor

Sensor Serial Number

Priority: 4

Source Address: Tilt Sensor

Data Content (PF): 0xFF (Proprietary B)

Data Content (PS): 0x52

Repetition Rate: On request

Data	Byte	Function
X	0	Serial Number in BCD (set = 00); populate extra positions with zero
X	1	Serial Number in BCD (set upper nibble=0; upper digit year of production→lower nibble; year of production; ex. 14 for 2014; AA)
X	2	Serial Number in BCD (set upper nibble=0; upper digit year of production→lower nibble; year of production; ex. 14 for 2014; AA)
X	3	Serial Number in BCD (lower digit of calendar week→upper nibble; reserved X→lower nibble)
X	4	Serial Number in BCD (most significant sequence digits; upper CC)
X	5	Serial Number in BCD (least significant sequence digits; lower CC)
X	6	Software Revision Major Number in BCD
X	7	Software Revision Minor Number in BCD

AXISENSE-G DUAL AXIS GYRO STABILIZED TILT SENSOR

Examples

Initial Inclination sensor sources address = 0xC0 (uninitialized), 0xE8 after change and 0xC0 again

Inclination sensor serial number = 174700286

Master source address = 0xC3

Data packet	Time in ms	Time delta in ms	In/Out	CAN Id	CAN Data	Comment
1	0	0	Rx	18EEFFC0	00 00 20 66 00 88 00 30	Address claim of inclinometer
2	57	57.6	Rx	10FF53C0	28 23 94 11 19 13 01 00	Tilt angle broadcast, sensor SA = 0xC0, X Angle = 0x2328 = 90°, Y Angle = 0x1194 = 45°, Temper. = 0x19 = 25 °C Softw. Ver. = 0x13 = 1.3x Data timest. = 0x0 = 0 Data status = 0x1 = valid Error code = 0x00 = no err transm. period = 10 ms
3	67	9.9	Rx	10FF53C0	28 23 94 11 19 13 11 00	...
4	77	9.9	Rx	10FF53C0	28 23 94 11 19 13 21 00	...
5	87	9.8	Rx	10FF53C0	28 23 94 11 19 13 31 00	...
6	97	9.9	Rx	10FF53C0	28 23 94 11 19 13 41 00	...
17	205	9.9	Rx	10FF53C0	28 23 94 11 19 13 F1 00	Maximum timestamp reached (0xF)
18	215	9.8	Rx	10FF53C0	28 23 94 11 19 13 01 00	Timestamp rollover (0x0)
19	225	9.9	Rx	10FF53C0	28 23 28 23 19 13 11 00	Continue with tilt angle broadcast
2688	26577	6.2	Tx	10FF54C3	00 00 00 00 00 00 00 00	Serial number command request
2689	26579	1.6	Rx	10FF52C0	00 01 74 70 02 86 01 36	Serial number answer in BCD = 174700286, Software Ver = 1.36
2690	26582	2.6	Rx	10FF53C0	9A 23 B1 22 19 13 E1 00	Tilt angle broadcast, X = 0x239A = 91.14°, Y = 0x22B1 = 88.81°
2691	26591	9.9	Rx	10FF53C0	9A 23 B1 22 19 13 F1 00	...
7957	249957	2	Tx	10FF54C3	01 E8 00 01 74 70 02 86	Change source address of sensor 174700286 S.N. to 0xE8
7958	250148	191.2	Rx	10FF53E8	92 23 B9 22 1E 13 A1 00	Tilt angle broadcast, source address has changed!
8872	259173	9.4	Tx	10FF54C3	02 00 00 01 74 70 02 86	Stop transmission
8874	262689	3515.5	Tx	10FF54C3	03 00 00 01 74 70 02 86	Start transmission again (3.515 seconds no answer)
8875	262695	5.8	Rx	10FF53E8	93 23 B8 22 1E 13 D1 00	Tilt angle broadcast
9247	266369	9.9	Tx	10FF54C3	04 04 00 01 74 70 02 86	Change transmission period to 0x04 = 40 ms
9250	266602	39.9	Rx	10FF53E8	91 23 B8 22 1E 13 31 00	Tilt angle broadcast with 40 ms transmission period
9251	266642	40	Rx	10FF53E8	90 23 B8 22 1E 13 41 00	...
9252	266682	40	Rx	10FF53E8	93 23 B8 22 1E 13 51 00	...

AXISENSE-G DUAL AXIS GYRO STABILIZED TILT SENSOR

Data packet	Time in ms	Time delta in ms	In/Out	CAN Id	CAN Data	Comment
9661	283009	20.7	Tx	10FF54C3	09 E8 00 01 74 70 02 86	Deinitialize sensor source address
9662	283089	80.1	Rx	10FF53C0	90 23 BA 22 1E 13 E1 00	Sensor's source address is 0xC0 again
9663	283129	39.9	Rx	10FF53C0	91 23 BB 22 1E 13 F1 00	...
9664	283169	40	Rx	10FF53C0	91 23 BB 22 1E 13 01 00	...
9805	288789	24.2	Tx	10FF54C3	00 00 00 00 00 00 00 00	Serial number command
9806	288790	1.6	Rx	10FF52C0	00 01 74 70 02 86 01 36	it's still 174700286
9807	288805	40	Rx	10FF53C0	90 23 BB 22 1E 13 D1 00	Tilt angle broadcast
9808	288845	40	Rx	10FF53C0	90 23 BA 22 1E 13 E1 00	...
9809	288885	40	Rx	10FF53C0	90 23 BA 22 1E 13 F1 00	End of trace

INSTALLATION AND MOUNTING INSTRUCTIONS

INTRODUCTION

This specification covers the requirements for mounting of inclination sensor modules from the AXISENSE Series. This series is mainly developed with focus on platform leveling, dynamic engine management, tip-over protection and tilt alarm. When corresponding with personnel, use the terminology provided in this specification to facilitate inquiries for information. Basic terms and features of this product are provided in Figure 6.



Figure 6: Sensor Terminologies

REFERENCE MATERIAL

Customer Assistance

Reference Product Type can be found on the label of the sensor starting with “AXISENSE-G”. Use of this name will identify the product type and help you to obtain product information. Such information can be obtained through a local Representative, by visiting our Website at www.te.com.

Drawings

Customer Drawings for product part numbers are available from the service network. If there is a conflict between the information contained in the Customer Drawings and this specification or with any other technical documentation supplied, the information contained in the Customer Drawings takes priority.

Specifications

Reference documents which pertain to the products are available via www.te.com or your personal point of contact at TE Connectivity.

AXISENSE-G DUAL AXIS GYRO STABILIZED TILT SENSOR

REQUIREMENTS

The sensor shall always be mounted according the specified mounting direction, which is floor mount (see Figure 7), “g” reflects the vector of gravity in zero position of both movement axes.

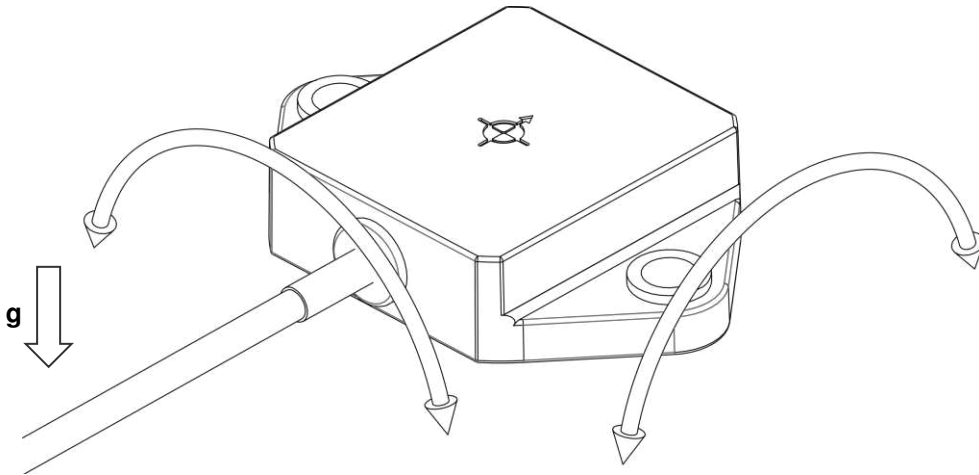

Figure 7: Mounting Reference to Gravity

To obtain the most accurate sensor outputs and prevent accelerated degradation over time, these items should be considered:

- Prevent from direct sunlight
- Avoid high relative humidity
- Avoid extreme temperatures close to the specified operational temperature limits
- Minimize number of temperature changes and temperature shift
- Select location with minimum acceleration from application (vibration, shock, centrifugal etc.)

A flat mounting area with a surface deviation of less than 0.15 mm must be chosen. No welding seams or surface bends should be present in the mounting footprint of the sensor housing. While installing the sensor do not exceed minimum bending radius of cable which (24 mm for static and 48 mm for use in dynamic application).

The recommended mounting torque is 10 Nm, which is also depending on the property class of the used screws (e.g. 6.8 class screw limits torque to 7.5 Nm). The applied mounting torque must not exceed 15 Nm.

AXISENSE-G DUAL AXIS GYRO STABILIZED TILT SENSOR

To achieve best accuracy of the output values, the reference edge of the housing, as highlighted in Figure 8, should be used. This edge complies with the alignment of the sensor module during the calibration process in factory. Figure 9 reflects these requirements and recommendations.

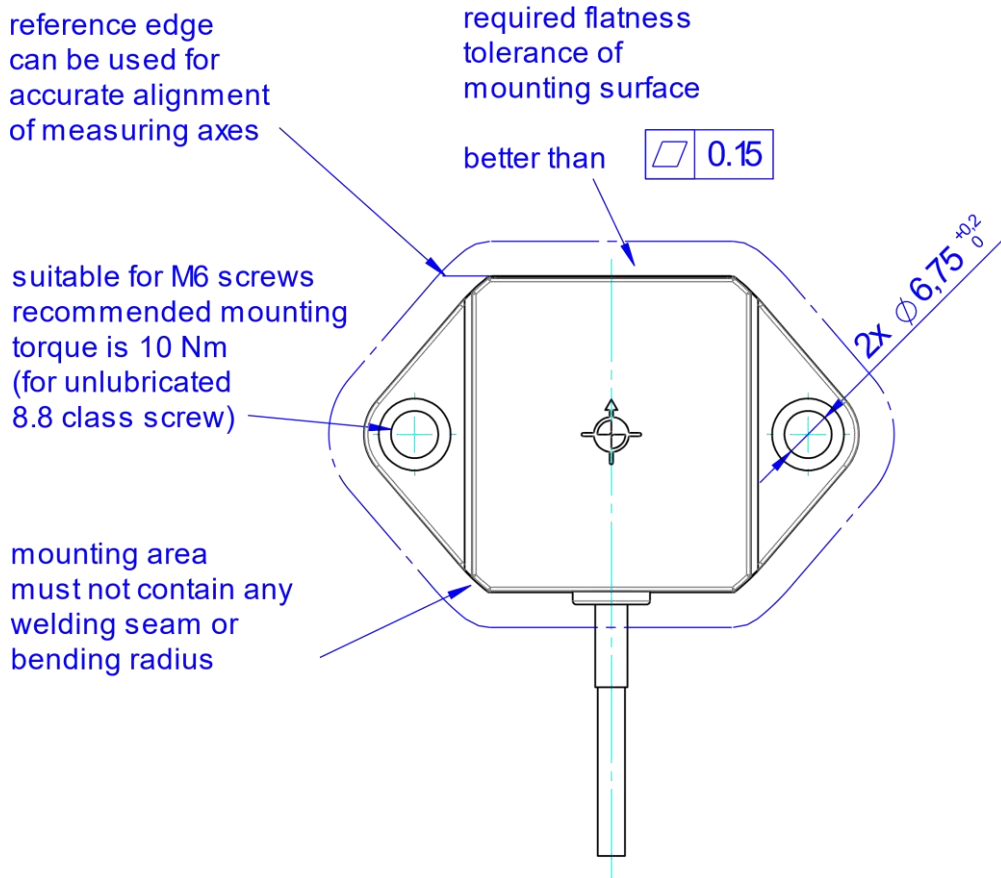

Figure 8: Mounting Detail

The sensor module should be mounted with screws onto a part already containing M6 size threaded holes separated by a distance of 56 ± 0.25 mm. Mounting of the sensor module with M6 hexagon nuts and threaded pins fixed to the part is also recommended as long as the required flatness below the sensor module is guaranteed (see Figure 9). It is advised to use a washer with the screw or hexagon nut in any of those cases.

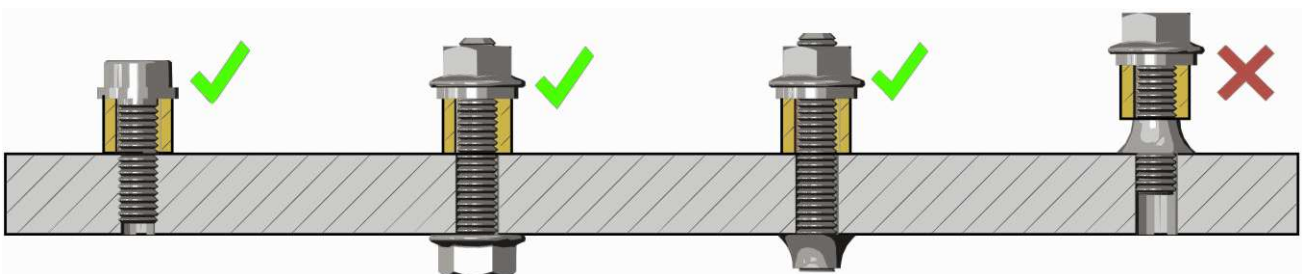

Figure 9: Mounting Screw Detail

AXISENSE-G DUAL AXIS GYRO STABILIZED TILT SENSOR

When the counterpart in application contains through holes and the module is mounted with screws and hexagon nuts, it is recommended to use the through hole dimension and distance displayed in Figure 10.

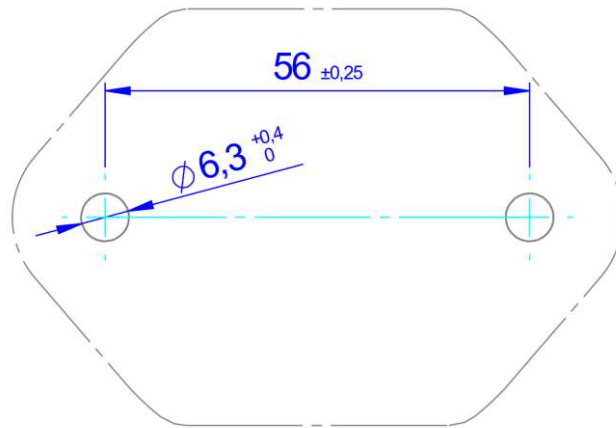

Figure 10: Mounting Hole Detail

In the case of an ideal alignment in application, the sensor axes would match exactly the axes to be measured. Using the minimum diameter for the through holes will reduce the possible deviation of the sensor module axes from ideal alignment. Thus, compared to the use of the maximum diameter, a better system accuracy can be achieved in application.

Beside limiting any undesired rotation, the maximum diameter of the through holes in the part shall be limited for another reason. Limiting the diameter to Ø6.7 mm will assure that the force onto the sensor housing emerged by the mounting torque of the screws applies only to the metal compression limiters of the sensor housing.

This is necessary, because it avoids the influence of mechanical stress caused by the mounting torque on other parts of the sensor module assembly. Otherwise, it would have a negative effect on the performance and accuracy of the system.

NOTE

All numerical values are in metric units. Dimensions are in millimeters. Unless otherwise specified, dimensions have a tolerance according to ISO 2768-mK. Figures and illustrations are for identification only and are not drawn to scale.

AXISENSE-G DUAL AXIS GYRO STABILIZED TILT SENSOR

Ordering Information

Part Number	Short Description
AXISENSE-G-700 10219046-00	Dual axis gyro stabilized tilt sensor, shock suppression, fast response, range $\pm 75^\circ$, Vcc 8-38 VDC, CAN J1939 Interface, customizable source address

The information given herein, including drawings, illustrations and schematics which are intended for illustration purposes only, is believed to be reliable. However, TE Connectivity makes no warranties as to its accuracy or completeness and disclaims any liability in connection with its use. TE Connectivity's obligations shall only be as set forth in TE Connectivity's Standard Terms and Conditions of Sale for this product and in no case will TE Connectivity be liable for any incidental, indirect or consequential damages arising out of the sale, resale, use or misuse of the product. Users of TE Connectivity products should make their own evaluation to determine the suitability of each such product for the specific application.

中国大陆
西安鑫源宇通电子科技有限公司
陕西省西安市高新区锦业路70号航
天恒星园区1号厂房一层南
Tel: 400-780-9688
sales@senstechxyz.com

中国香港
深大实业有限公司
香港新界沙田安平街6号新贸易
中心B座13楼06室
Tel: +86 17792099916
info@caltropinstruments.com

新加坡
深大实业有限公司
香港新界沙田安平街6号新贸易
中心B座13楼06室
Tel: +86 17792099919
info@senstechxyz.com