



OPTIMUS VERSION-2 PRESSURE SCANNING SYSTEM

- Windtunnel Pressure Scanning System
- ESP Pressure Scanner Compatible
- Up to +/- 0.03% Accuracy
- DTC Digital Temperature Compensation
- On Line Calibration
- On Line Verification

Features

- Miniature interface
- DTC technology
- Sensor excitation feedback
- Pressure calibration units
- Fiber optic communication

Benefits

- Direct placement within model
- Highest industry accuracy
- Stable readings
- Fast, accurate calibration & verification
- Low noise

The Optimus Data System is a pressure scanning solution designed specifically for windtunnel applications. The Optimus System Processor manages a configurable measurement solution that provides high precision and throughput data for up to 2048 measurement channels. Pressure is measured with ESP Miniature Pressure Scanners or MicroScanners, and then converted to a digital value within the Miniature Scanner Digitizer Interface (mSDI) units. Engineering Unit measurement values are calculated within the Optimus System Processor and reported via Ethernet at data rates up to 1Gbit/second. Users preferring to calculate engineering unit data in their own host computer can receive measurement values in binary format via the Ethernet interface.

System components include Pressure Calibration Units (PCU) to provide precise pressure calibration and performance verification information prior to start of test. Optimus Fiber Optic Interface Units (OFIU), combined with the mSDI, utilize single fiber cable to provide noise free communication between the pressure scanners and system processor.

Version-2 updates the main processor board of the Optimus System Processor. This new quad-core processor runs an updated revision of the Linux Operating System with improved Precision Time Protocol Stability. Version-2 performance focus is on data quality with averaged readings, away from high throughput without averaging.

New differential PCU's capable of operating to 35 psia line pressure have been introduced for operators of moderately pressurized windtunnels to perform on-line calibration. DTC technology and absolute PCU's support operators of highly pressurized windtunnels.

System Introduction

The Optimus Data System provides accurate high speed pressure acquisition of ESP and MicroScanner Pressure Scanner data for windtunnel test and measurement applications. The system is configurable for low speed, transonic, supersonic and hypersonic windtunnels with low and high channel count requirements.

Pressure Scanners are placed within or near the test object and connected to the measurement points on the test object using flexible tubing. Multiple scanners are connected to the mSDI Miniature Scanner Digitizing Interface which can be placed within the windtunnel model, sting or any convenient location up to 150 ft away from the scanners. The mSDI and 8491 Remote Power Supply, RPS, combine to provide precise excitation voltage to the scanners using individual scanner excitation feedback with active compensation. Each mSDI can support up to 8 ESP or MicroScanner pressure scanners in any combination. Analog to Digital conversion takes place within the mSDI and is transmitted via fiber optic cable to the OFIU fiber optic interface units within the Optimus System Processor. Each OFIU supports one mSDI. Up to 4 OFIU/mSDI are supported with each Optimus. Ethernet interface to the host computer can provide engineering unit value data or binary data for users preferring to perform engineering unit calculation within the host computer.

Pressure Calibration Units provide precise reference pressures to perform on-line calibration or provide verification pressures before testing is performed. Span calibration of ESP DTC-Style scanners before use provides the highest available accuracy.

Optimus provides a convenient upgrade path for 8400 System users by utilizing much of the same command set and offering compatibility with 8400 components such as: 8432/8433 Pressure Calibrators, 8491 Remote Power Supplies, 8404 Remote Processors and ESP Pressure Scanners.

Optimus is compatible with the latest MicroScanner and Gen-2 ESP pressure scanners as well as legacy ESP scanners manufactured by the former Pressure Systems Inc., which is now the Aerodynamic Research Group within Measurement Specialties Inc., a TE Connectivity company

System Diagram

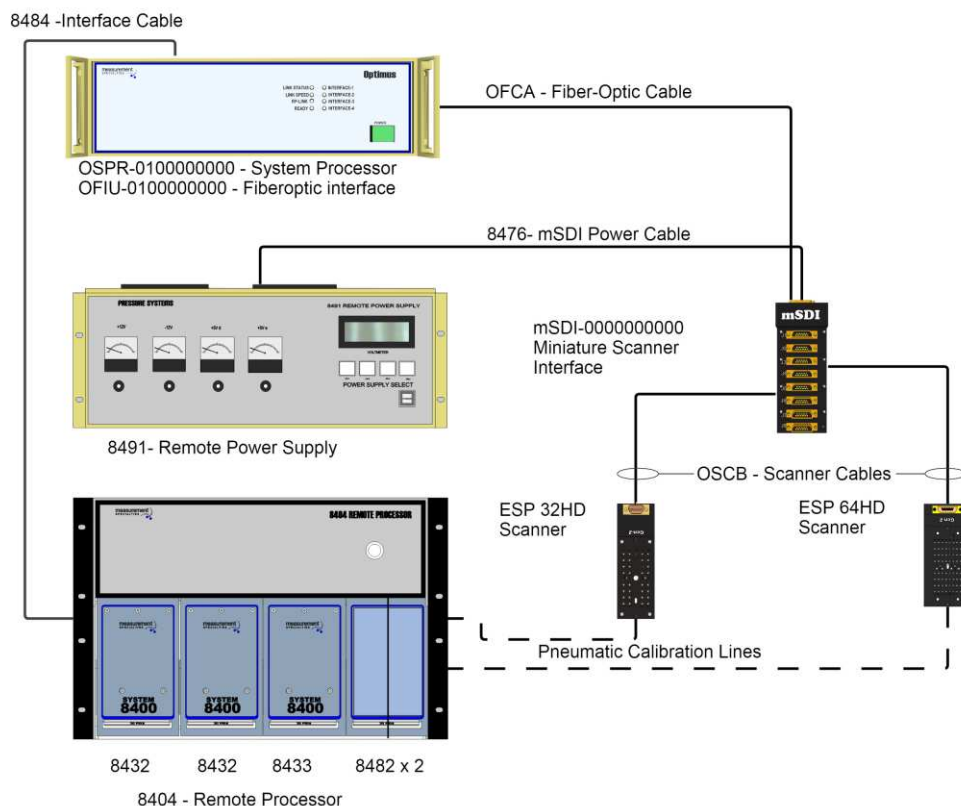

Optimus System Processor (OSP)

The Optimus System Processor (OSP) is the central data acquisition and control unit of the Optimus Pressure Scanning System. Configured for 19-inch rack or bench top installation, the OSP can support up to 32 pressure scanners for a total of 2048 measurement channels. Ethernet interface allows direct host interface, networked host interface, and expansion beyond 2048 measurement channels.

OFIU's are installed inside the OSP to communicate with the mSDI. A minimum of one OFIU is required for system operation and up to four OFIU's can be installed within one OSP. The OFIU's can be factory installed at time of system production or can easily be installed by the end user.

Data acquisition is initiated by the host computer which instructs the OSP to: acquire only one data point per request, stream data at specified rates, or send data upon receipt of a hardware trigger. Data output is flexible and can consist of multiple averages with engineering unit output. Data can also be delivered in raw binary format for users who prefer to perform averaging and or engineering unit calculations within the host computer.

Maximum performance of Optimus is achieved with current production ESP and MicroScanner pressure scanners. Accuracy, throughput, cable length and other limitations may exist with previous generations of ESP pressure scanners.

Optimus Fiber Optic Interface Unit (OFIU)

The Optimus Fiber Optic Interface Unit is a system component inside the OSP. It is a module that provides noise free data communication via 62.5 micron multimode fiber cable between the OSP and the mSDI scanner interface. The fiber-optic cable extends the OSP to mSDI distance. The thin flexible cable lets users place the mSDI within windtunnel models and bring data through the sting and perform simultaneous pressure and force balance measurements.

Each OFIU interfaces with one mSDI. A minimum of one OFIU is required for system operation with a maximum of four OFIU's able to be installed inside each OSP. The cable termination is via industry standard ST fiber optic connectors which are pre-installed within each OSP. The number of OFIU's to be installed is specified at time of order. Existing systems can be expanded by the user with the installation of additional OFIU's.

Miniature Scanner Digitizing Interface (MSDI)

The Miniature Scanner Digitizing Interface (mSDI) is the connection point for the cables leading to the pressure scanners. The mSDI provides regulated power to the scanners, facilitates excitation feedback measurement and conducts analog to digital (A/D) conversion at high data rates.

The small size and low power dissipation of the mSDI makes it ideal for locating inside of most windtunnel models. Cross sectional area was designed to match the ESP-64HD scanner, allowing the mSDI to be placed in-line with the pressure scanners for maximum channel density.

Data interface from the mSDI to the OFIU is via the Optimus Fiber Optic Cable (OFCA) is terminated using industry standard ST connectors. Power is supplied from the 8491 Remote Power Supply (RPS) which in turn is distributed to each pressure scanner via the mSDI. The mSDI connects to the ESP pressure scanners with the Optimus Scanner Cable (OSCB), which can vary between 6 inches and 150 feet in length when using the latest Gen-2 version of ESP pressure scanners. Pressure scanner installation can vary between one 16 channel scanner and eight 64 channel scanners, all on different length OSCB cables. OSCB cables utilize standard miniature sub-D 15-pin connectors to mate with all standard ESP pressure scanners.



Remote Power Supply (RPS)

The Remote Power Supply (RPS) provides precisely regulated power to the mSDI which in turn distributes the power to the connected pressure scanners. The +12, -12, and +5VDC power rails are monitored and automatically adjusted to ensure proper voltage levels are maintained, even when power demands vary from temperature variations, cable length variations or any mixture of legacy and new scanners.

The RPS connects to the mSDI with the 8476 cable, or user manufactured equivalent, which can vary between 1 and 300 ft in length. The RPS uses excitation sense feedback to constantly monitor and adjust power to ensure proper excitation signals to the scanners under different configurations. This monitoring and adjustment also corrects for temperature induced changes in cable resistance during use.

The RPS is configured for 19-inch rack mount installation or bench mount use. Each RPS can support two mSDI. Multiple RPS are required for installations with more than two mSDI.

The 8476 cable can connect to one mSDI or the Optimus Fiber Optic Y-Cable (OFCY) can be used to split the 8476 power to two separate mSDI.

The RPS is a Legacy 8400 System Product. Users with existing 8400 Systems considering upgrading to Optimus may require a minor modification to their existing RPS to be compatible with the latest generation of pressure scanners. Please contact the factory for details.

Pressure Calibration Unit (PCU)

The Pressure Calibration Unit (PCU) is a high accuracy servo-controlled pressure generation instrument. Its function is to provide accurate and precise pressure to the ESP Scanners for performing calibration or pre-test verification. System configuration allows the user to pre-program the pressure set points to use during calibration. When commanded to start a calibration sequence the PCU sets and reports the exact pressure applied to the pressure scanners. Use of a PCU can provide system accuracy better than $\pm 0.03\%$ Full Scale (FS). The pressure range of the PCU is selected to match the pressure range of the scanner for most accurate calibration. The system is designed to use multiple PCU's in parallel to perform rapid and precise calibration for configurations using a variety of measurement pressure ranges during one test. Up to twelve different pressure ranges and a total of 2048 measurement channels can be calibrated in parallel in approximately 90 seconds.

Each PCU uses externally supplied source pressure brought in from the pneumatic backplane of the Remote Processor (RP) then precisely regulates and maintains the desired calibration pressure. Users interface to the PCU via software commands to the OSP. Typical calibration consists of 2-5 pressures set in succession over the span of the pressure scanners measurement range. The PCU's are also used to perform an Auto Accuracy Test (AAT) where the user sets specific pressures and verifies accuracy of the ESP Pressure Scanners.

The PCU is also available as a measurement-only instrument called the Pressure Standard Unit (PSU). The PSU has the same physical configuration as the PCU, incorporates the same high accuracy measurement sensor but without the controller hardware. The purpose of the PSU is to measure and continuously monitor important windtunnel pressures not associated with the primary test object measurement. Barometric pressure, tunnel static pressure and tunnel wall pressures are all examples of measurements made with PSU's. The PCU can also operate in measurement-only mode, like the PSU, allowing it to be used to make measurements while not being used to set pressures.

PCU's and PSU's are Legacy 8400 System Products. Users with existing 8400 Systems considering upgrading to Optimus may use existing PCU/PSU without modification.

Remote Processor (RP)

The 8400 Remote Processor (RP) is a rack mounted interface for the PCU and PSU. It provides a complete pneumatic, electrical and communications interface for the PCU and PSU. Up to four PCU/PSU can be mounted within one RP. All pneumatic connections are conveniently routed through a unique pneumatic bus on the backplane of the RP, allowing convenient and automatic pressure connection between the PCU/PSU supply pressure and output to the pressure scanners.

The RP is a rack mounted instrument that can be mounted near the OSP, or remotely near the pressure scanners. Mounting the RP closer to the pressure scanners reduces the length of the pressure calibration lines which may improve calibration speed due to reduced pressure settling time in the large volume associated with long calibration lines.

The RP communicates to the OSP via serial RS-485 using the 8484 cable and contains an internal power supply for AC input compatibility. Up to three RP's can be connected to one OSP for a total interface of 12 PCU/PSU.

The RP and associated cables are Legacy 8400 System Products. Users with existing 8400 Systems considering upgrading to Optimus can use properly operating units without modification or service requirements.

System Cables

The Optimus System incorporates a variety of function-specific cables to achieve highly accurate, fast and reliable operation for a broad range of windtunnel types. Each cable has been carefully selected and designed to achieve specific functions common to most windtunnels. Detailed cable diagrams and cable design assistance are available to users desiring to manufacture custom cables to meet requirements unique to their own installation. It is recommended to have one complete set of factory produced cables for troubleshooting purposes. The following describes the function of each cable, starting with connections at the pressure scanners.

OSCB – Optimus Scanner Cable - The OSCB connects ESP pressure scanners to the mSDI scanner interface. It is available in lengths from 6-inches to 150-feet. Any combination of cable lengths can be utilized since the RPS automatically adjusts system power load and pressure scanner excitation on a per-scanner basis. The OSCB is an improved version of the PSCB cable with specific shielding and pin locations to minimize power to signal interference. The connector gender has been changed at the mSDI to prevent accidental reversal of the cable while maintaining standard ESP/MicroScanner pressure scanner connector compatibility. A PSCB cable may be modified to functional equivalent of OSCB cable with connector change for lengths up to 90 ft. The OSCB cable has one additional shield wire connected at scanner end which provides improved performance for lengths over 90 ft.

OFCA – Optimus Fiber Optic Cable - The OFCA provides noise free data communication between the mSDI scanner interface and the OFIU fiber optic interface located within the OSP. Industry standard, reliable metallic ST connectors are used at both ends of the cable. Full duplex communication between the mSDI and OFIU allows the use of just one fiber to simultaneously transmit and receive reliable high speed communication between the two system components. The mSDI and OFIU communicate at 1310 and 1550 nm via 62.5 micron multimode fiber, allowing existing 8400 users to utilize existing 8474 fiber optic cables without modification. We offer OFCA cables in lengths up to 300-feet (91m). The system has been verified for use with cables up to 1 kilometer.

8476 Power Cable - The 8476 provides accurate, regulated power to the mSDI from the RPS. It is available in any length between 1-foot and 300-feet. Existing 8400 users can use existing 8476 cables without modification.

OPCY Y-Cable - The Y-Cable connects the 8476 cable and mSDI. It functions as a splitter to expand RPS power to two separate mSDI. Excitation feedback to provide the required precise scanner excitation is maintained with this cable design. The two legs of the Y-Cable can be different lengths with an overall length limitation of 6 ft.



Software Commands and 8400 Command Set Compatibility

The Optimus utilizes much of the same command set as the 8400 System. Commonly used 8400 commands have been preserved. Most 8400 users will be able to convert existing installations with a minimum of software investment. Command list review with a factory applications engineer is recommended for 8400 users planning to re-use existing software.

Utility Software

Windows compatible start up software is provided at no charge with the system and via our website. The software allows users to quickly operate a complete system to confirm system operation, acquire data, log data and analyze data. It also provides convenient program development support by allowing users to send and receive responses to specific programming commands. Many convenient functions are included which may be used independent of user run time software, such as:

- A. Auto System Configuration – Identifies system components based on DTC technology
- B. System Calibration – Coordinates calibration of all scanners with appropriate calibrators
- C. Auto Accuracy Test – Utility to perform automated system calibration and accuracy test
- D. Channel Check – Utility to confirm proper tubing connections within model
- E. IP Address Change – Configures system to match network parameters
- F. Scanner Utilities – Monitors and configures important pressure scanner parameters
- G. Real Time FFT – Excel link to analyze high speed data

Physical Specifications										
Parameter	OSP	OFIU	mSDI	RPS	PCU	RP	PBU	ESP	Units	Comments
Physical										
Capacity	1	1-4	1-4	1-4	1-12	1-3	6 max required	1-32	Units	Expandable via Ethernet
Material	Steel & Aluminum-Painted	Printed Circuit Boards	Aluminum-Anodized	Steel & Aluminum-Painted	Aluminum Iridited & Painted	Aluminum Iridited & Painted	Aluminum Iridited & Painted	Steel & Anodized Aluminum		
Environmental										
Operating Temperature	0-50	0-50	-25 to 80	0-50	0-50	0-50	0-50	-25 to 80	°C	
Storage Temperature	0-80	0-80	-25 to 100	0-80	0-80	0-80	0-80	-25 to 100	°C	
Relative Humidity	5-95	5-95	5-95	5-95	5-95	5-95	5-95	5-95	%	Non-Condensing
Vacuum & Pressure	10-16	10-16	0.0002 to 150	10-16	10-16	10-16	10-16	0.0002 to 150	PSI Absolute	
Vibration	N/A	N/A	10	N/A	N/A	N/A	N/A	10	g at 15 to 2000 Hz	
Shock	N/A	N/A	30	N/A	N/A	N/A	N/A	30	g Peak	
Sealing	IP-20	N/A	IP-50	IP-20	IP-40	IP-20	IP-50	IP-40		
Connections										
Electrical Input	AC	Internal from OSP	From RPS	AC	Internal to RP	AC	N/A	From mSDI		
Electrical Output	Ethernet & RS-485	Internal to OSP	To ESP	To mSDI	Internal to RP	RS-485 to OSP	N/A	To mSDI		
Fiber Optic	via OFIU	To mSDI	To OFIU	N/A	N/A	N/A	N/A	N/A		
Pneumatic	N/A	N/A	N/A	N/A	Internal to RP	To ESP	Seals Unused RP Slots	Measurements from model & Cal via RP/PCU		
Power										
Power Input	Universal 100-240	Internal from OSP	From RPS	Specified 100, 110, 220	From RP	Specified 100/110, 220	N/A	From mSDI	V olts AC	50 or 60 Hz

Performance Specifications - DTC ESP Scanners					
	MicroScanner 16 DTC	ESP-32HD DTC Gen-2	ESP-64HD DTC Gen-2	Units	Comments
Number of Pressure Inputs	16	32	64	Ports	
Throughput In Engineering Units	20	10	5	Hz Per Port	64 point averaging.
Resolution	0.001	0.001	0.001	± % Full Scale	Noise Floor Analysis
Static Accuracy at Full Range 5 to 150 psid	0.1	0.03	0.03	± % Full Scale	64 point averaging
Static Accuracy at 33% Range 10 to 150 psid	0.15	0.05	0.05	± % Full Scale	64 point averaging
Static Accuracy at Full Range 10" WC to 2.5 psid	N/A	0.06	0.06	± % Full Scale	64 point averaging
Static Accuracy at Full Range 4" WC	N/A	0.15	0.15	± % Full Scale	64 point averaging
Total Thermal Effect at Full Range 5 psid to 150 psid	0.002	0.002	0.002	± % Full Scale Per °C	
Total Thermal Effect at 33% Range 10 psid to 150 psid	0.003	0.003	0.003	± % Full Scale Per °C	
Total Thermal Effect at Full Range 10" WC to 2.5 psid	N/A	0.004	0.004	± % Full Scale Per °C	
Total Thermal Effect at Full Range 4" WC	N/A	0.010	0.010	± % Full Scale Per °C	
Maximum Reference Pressure	50	50	50	PSI Differential	
Line Pressure Effect	0.001	0.001	0.001	± % Full Scale Per PSI	

System Configuration and Ordering Information

The following items are required to configure an Optimus Pressure Scanning System. Please coordinate with your factory contact or local distributor to determine appropriate options, potential re-use of existing 8400 equipment, part numbers and pricing.

- OSPR** Optimus System Processor, Universal AC, Rack and Bench Mount, Completely Configured
- OFIU** Optimus Fiber Optic Unit, PC Board for installation within Optimus System Processor
- Installed by Factory
 - Installed by User
- mSDI** Miniature Scanner Digitizing Interface, up to 8 ESP scanners, Completely Configured
- RPS** Remote Power Supply, for use with 1 or 2 mSDI
- Power, 100, 110 or 220 VAC
 - Upgrade required if re-using existing unit
- PCU** Pressure Calibration Unit, used for calibration, located within RP or LS
- Pressure range
- PBU** Pneumatic Blanking Unit, used to fill unused slots of RP or LS
- RP** Remote Processor, communicates with OSP, contains PCU's, provides calibration to scanners
- OSCB** Scanner cable, connects ESP to mSDI
- Length, min 6 inches, max 150 ft with Gen-2 ESP scanners, max 30 ft with other ESP scanners
 - Jacket material, PVC standard, PTFE optional
- OFCA** Fiber Optic Cable, ST connectors, single fiber, connects mSDI to OFIU, available up to 91 meters
- 8476** Power cable, RPS to mSDI
- Length, 300 ft max
 - Connector type for RPS connection, circular for new installations, d-shell for replacement only
- OPCY** Y-Cable, splits 8476 cable for use with 2 mSDI, total length 6 ft
- Length of left portion
 - Length of right portion
- ESP** Pressure Scanners
- MicroScanner or ESP
 - Pressure range
 - Connection size
 - Quick disconnect plate
 - With or without purge
 - Digital Temperature Compensation or Conventional

The information given herein, including drawings, illustrations and schematics which are intended for illustration purposes only, is believed to be reliable. However, TE Connectivity makes no warranties as to its accuracy or completeness and disclaims any liability in connection with its use. TE Connectivity's obligations shall only be as set forth in TE Connectivity's Standard Terms and Conditions of Sale for this product and in no case will TE Connectivity be liable for any incidental, indirect or consequential damages arising out of the sale, resale, use or misuse of the product. Users of TE Connectivity products should make their own evaluation to determine the suitability of each such product for the specific application.

中国大陆
西安鑫源宇通电子科技有限公司
陕西省西安市高新区锦业路70号航
天恒星园区1号厂房一层南
Tel: 400-780-9688
sales@senstechxyz.com

中国香港
深大实业有限公司
香港新界沙田安平街6号新贸易
中心B座13楼06室
Tel: +86 17792099916
info@caltropinstruments.com

新加坡
深大实业有限公司
香港新界沙田安平街6号新贸易
中心B座13楼06室
Tel: +86 17792099919
info@senstechxyz.com

