

PRECISION REACTION TORQUEMETERS

STATIONARY FOIL GAGE SENSORS FOR ROTATING & NON-ROTATING APPLICATIONS

10 ozf-in thru 2,400,000 lbf-in capacities

See Bulletin 772 For Solid Flanged Reaction Torquemeters with mV/V or ± 10 Volt Outputs

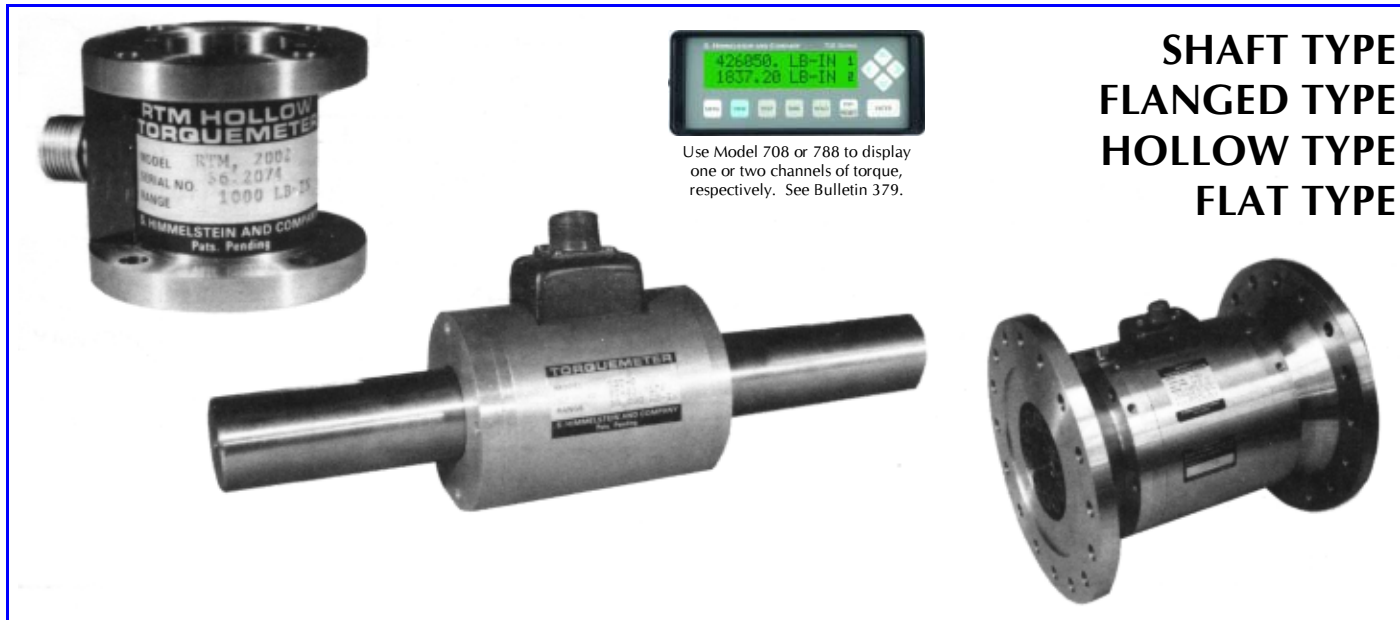

REACTION TORQUE MEASUREMENTS

Permit accurate determination of static and dynamic torque with a stationary (non-rotating) transducer even though the device under test may be rotating at high speed. Reaction torque measurements are based on Newton's third law of angular motion which states, "when a body exerts a torque upon another body, the second exerts an *equal torque* upon the first in the *opposite* direction and about the same axis of rotation." Referring to **Figure 1**, the reaction torque path must be through the torque meter, so the torque meter will accurately measure torque applied to the clutch and, with appropriate electronics, the test set-up can readily determine peak or slip torque.

Figure 2 shows how a hollow reaction torque meter is used to measure the output torque of an air tool. The torque meter will accurately measure the instantaneous tool output torque even though it rises rapidly (in milliseconds) as the fastener seats. However, all the reaction torque must pass through the torque meter - a rotating union (or equal) must be used at the air supply end to eliminate shunting part of the reaction torque through the air lines and thus producing a measurement error. Although it is possible to satisfy this requirement (no unwanted shunt torque paths) in an air tool application other potential applications can have significant, unavoidable shunt torque paths which, in turn, will limit the accuracy of the reaction measurement. An in-line torque measurement should be used in such cases.

(Continued on page 4)

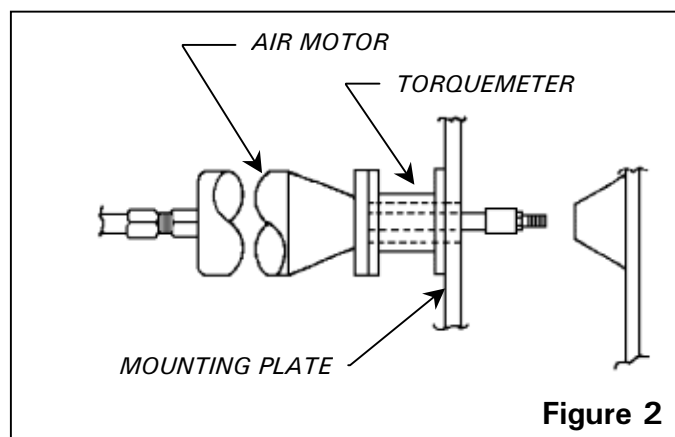
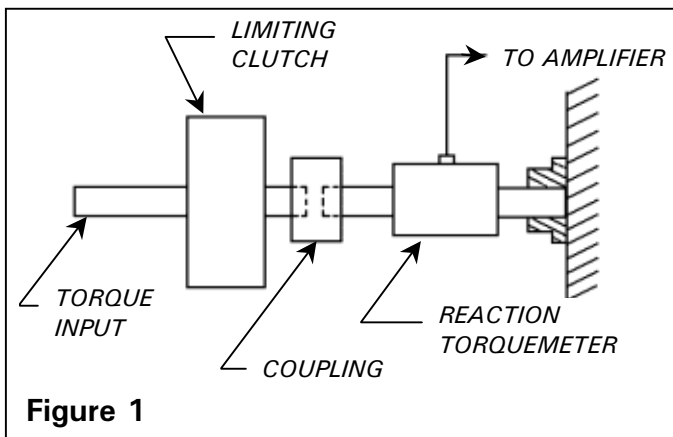

S. HIMMELSTEIN AND COMPANY

2490 Pembroke Avenue, Hoffman Estates, IL 60169 USA • Tel: 847/843-3300 • Fax: 847/843-8488

Dimensional Outlines

S. Himmelstein and Company Reaction Torquemeters

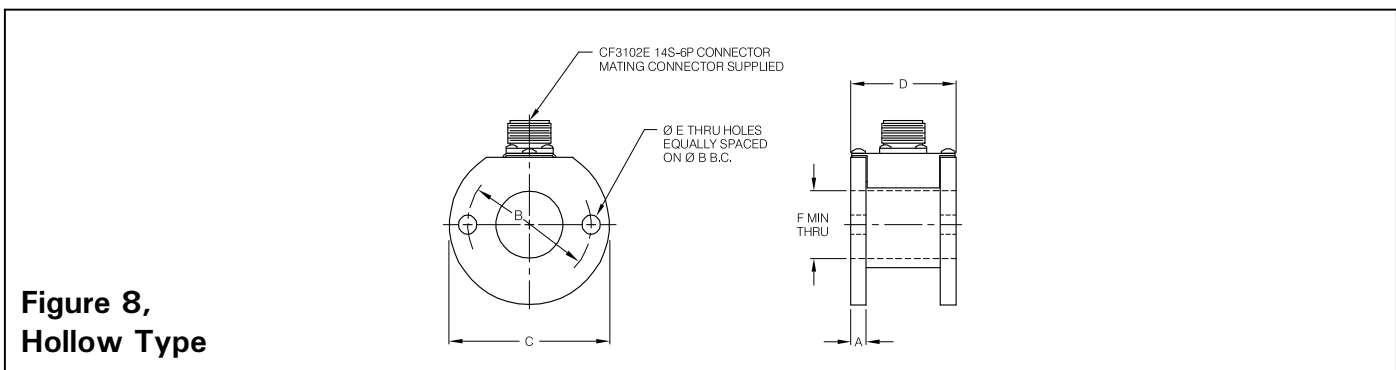
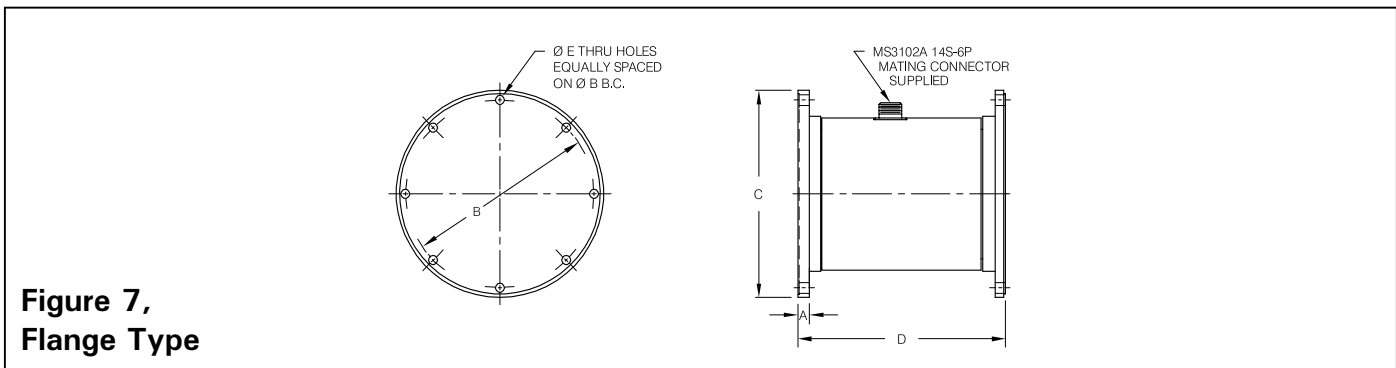
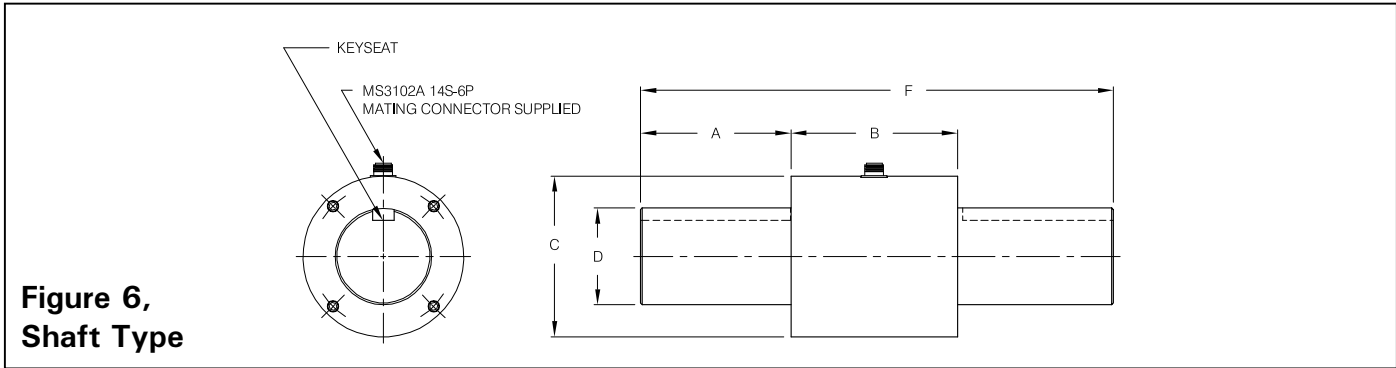
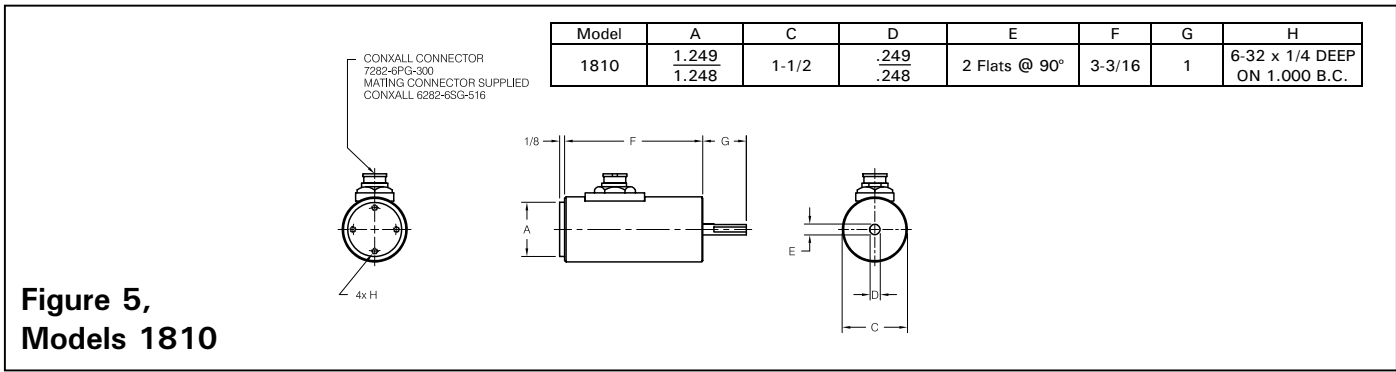

Electrical Connections

PIN	FUNCTION
A	+ EXCITATION
B	+ EXCITATION SENSE
C	- EXCITATION SENSE
D	- EXCITATION
E	- SIGNAL
F	+ SIGNAL

Complete Systems

When supplied with precision reaction torquemeters, Himmelstein systems include solid state readout, interconnecting cable, system checkout and NIST traceable dead weight calibration. You receive an operating system with guaranteed system performance, single source system responsibility and a full one year system warranty.

Signal Polarity

Hollow Type: Positive for CCW torque through the torquemeter.

All Other Types: Positive for CW torque through the torquemeter.

Reaction Torquemeters – Standard Ratings

TYPE	MODEL NUMBER	RANGE (lbf-in)	TORSIONAL STIFFNESS (lbf-in/rad)	MAXIMUM EXTRANEIOUS LOADS		DIMENSIONS (inches)					
				THRUST F (lbs)	BENDING MOMENT W x D (lb-in)	A	B	C	D	E	F
SHAFT TYPE See Figure 6	1810(1-1)	10*	230*	40*	100*	SEE FIGURE 5					
	1810(25-0)	25*	883*	80*	150*						
	1810(5-1)	50*	2,100*	100*	200*						
	1810(1-2)	100*	4,670*	150*	250*						
	1810(16-1)	160*	7,650*	150*	300*						
	1850A(2-4)	20,000	3,800,000	20,000	9,500	5-1/8	8-3/4	5-1/2	3,000 +0/-0.001	3/4 Square	19
	1850A(5-4)	50,000	5,700,000	48,000	23,250	5-1/8	8-3/4	5-1/2		3/4 Square	19
	1850A(1-5)	100,000	7,100,000	65,000	47,000	5-1/8	8-3/4	5-1/2		3/4 Square	19
	1850A(2-5)	200,000	29,000,000	70,000	98,000	7-1/8	7-3/4	7-1/2	4,500 +0/-0.001	1 Square	22
	1850A(3-5)	300,000	32,700,000	75,000	147,000	7-1/8	7-3/4	7-1/2		1 Square	22
FLANGE TYPE See Figure 7	1930(18-3)	18,000	4,820,000	18,000	9,000	3/8	7-1/4	8	8	8, 0.377D	N/A
	1930(25-3)	25,000	6,830,000	25,000	12,000	3/8	7-1/4	8	8	8, 0.377D	N/A
	1930(3-4)	30,000	8,220,000	30,000	15,000	3/8	7-1/4	8	8	8, 0.377D	N/A
	1930(48-3)	48,000	12,200,000	48,000	24,000	3/8	7-1/4	8	8	8, 0.377D	N/A
	1930(6-4)	60,000	14,400,000	50,000	30,000	3/8	7-1/4	8	8	8, 0.377D	N/A
	1930(96-3)	96,000	17,900,000	52,000	40,000	3/8	7-1/4	8	8	8, 0.377D	N/A
	1940(2-5)	200,000	37,500,000	60,000	90,000	3/4	10-3/8	12	13	16, 0.630D	N/A
	1940(3-5)	300,000	42,800,000	70,000	150,000	3/4	10-3/8	12	13	16, 0.630D	N/A
HOLLOW FLANGE TYPE See Figure 8	2010(6-1)	60	98,500	100	50	5/16	2	2-1/2	2-1/8	2, 0.203D	7/8
	2010(12-1)	120	98,500	120	60	5/16	2	2-1/2	2-1/8	2, 0.203D	7/8
	2020(24-1)	240	171,400	240	120	5/16	2	2-1/2	2-1/8	2, 0.203D	7/8
	2030(6-2)	600	712,000	600	300	5/16	2-1/2	3-1/4	2-1/8	2, 0.390D	1-3/8
	2030(12-2)	1,200	1,420,000	1,200	600	5/16	2-1/2	3-1/4	2-1/8	2, 0.390D	1-3/8
	2050(3-3)	3,000	3,340,000	3,000	1,500	5/16	3-3/8	4	2-1/8	4, 0.406D	2-3/8
	2050(6-3)	6,000	7,970,000	6,000	3,000	5/16	3-3/8	4	2-1/8	4, 0.406D	2-3/8
	2060(1-4)	10,000	8,380,000	2,500	2,250	5/8	4-3/8	5	3-1/2	6, 3/8-24 UNF	3-3/8
	2060(2-4)	20,000	14,300,000	5,000	4,500	5/8	4-3/8	5	3-1/2	6, 3/8-24 UNF	3-3/8
	2070(5-4)	50,000	36,800,000	10,000	10,000	5/8	7	8-1/2	3-1/2	8, 0.630D	3-3/8
	2070(1-5)	100,000	51,200,000	20,000	20,000	5/8	7	8-1/2	3-1/2	8, 0.630D	3-3/8
	2090(12-5) ⁵	1,200,000	3,500,000,000	480,000	480,000	3/4	19.00	21.00	5	32, 0.812D	14.25
	2090(18-5) ⁵	1,800,000	3,900,000,000	600,000	600,000						
	2090(24-5) ⁵	2,400,000	4,300,000,000	720,000	720,000						
FLAT TYPE	2137(5-1)	50	10,100	500	250	SEE FIGURE 9					
	2137(1-2)	100	46,200	500	250						
	2137(2-2)	200	129,000	500	250						
	2137(5-2)	500	506,000	500	250						

Figure 9, Flat Type (Model 2137)

NOTES:

- * Torque is in ozf-in, stiffness is ozf-in/radian, thrust is in oz's.
- 1. Torsional stiffness value includes shaft extensions, where they exist.
- 2. All units are stainless steel except Models 2010 and 2137, which are aluminum.
- 3. See Page 4 (overleaf) for a definition of extraneous loads.
- 4. See Page 4 for General Specifications applicable to all Models; includes output, torque overload capacity, temperature effects, etc.
- 5. Torquemeter has connector on 18" pigtail, see Bulletin 779.

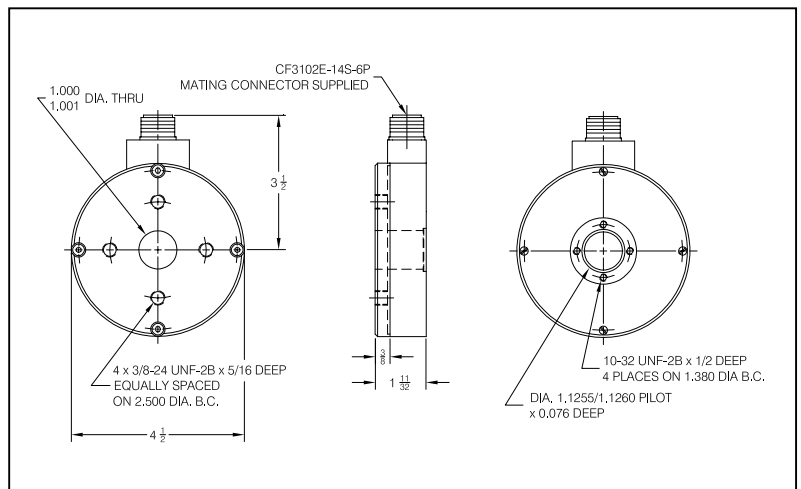
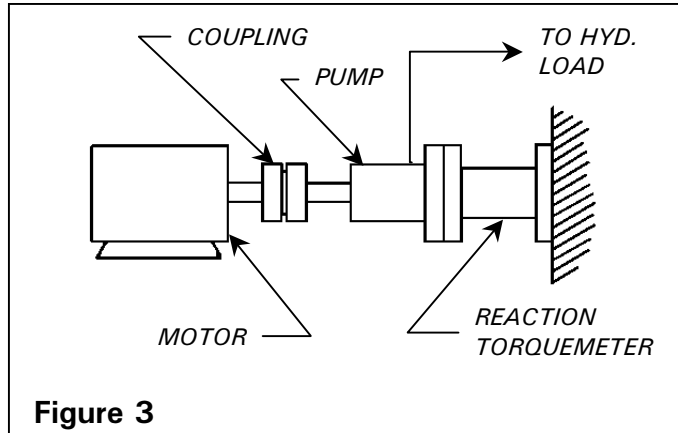
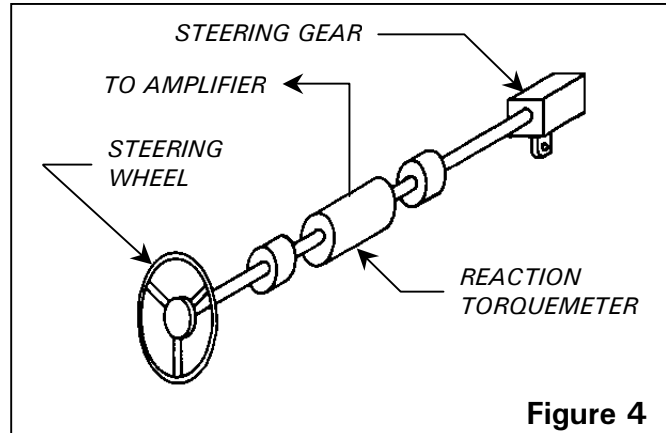

Figure 3 illustrates a measurement similar to that of Figure 2 but with a significant and very basic difference. Here the torquemeter measures the reaction of the power absorbing device instead of the power producing device. The torquemeter will measure the total reaction torque of the absorber but that torque is not necessarily equal to the output torque of the motor. For example, when the system is being accelerated (or decelerated), the motor output torque is equal to the torque required to accelerate the output shaft (the product of angular acceleration and total load inertia - including absorber rotor, intermediate shaft and couplings), the windage torque of the total load and the real torque load of the absorber. In a set-up



like this, no reaction measurement will see either the acceleration or windage torques and, as a result, it will be in error to the extent such torques exist. The acceleration torque error component disappears when a shaft is at a constant speed but windage errors are always present. Only in-line torque measurements are immune to these error sources.

Reaction torquemeters are an economical solution where in-line measurements are required but where angular motion is restricted and cycle rates are low thus permitting cable "wind-up". Figure 4 illustrates such an application.



EXTRANEOUS LOADS

Any force or moment the torquemeter sees other than the reaction torque input is an extraneous load. Depending on installation (see illustration), these could include bending moments and axial thrust (tension or compression). The tabulation summarizes the maximum safe extraneous load that can be applied to the torquemeter assuming they are applied singly. Crosstalk errors from such loads will be typically 1% or less and, assuming they are constant, can be electrically zeroed.

- W** = weight of test item
- F** = thrust force, if any
- d** = distance to test item center of gravity
- Wxd** = bending moment

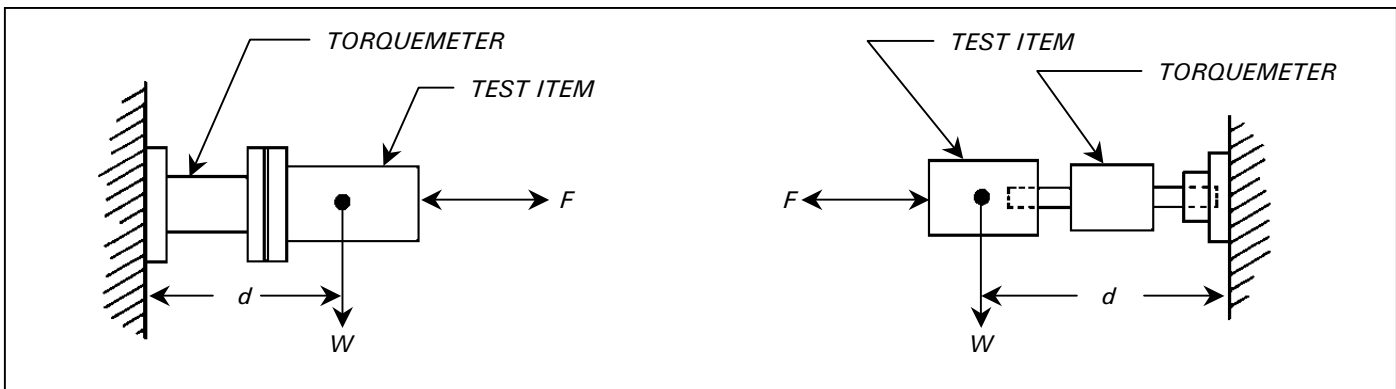

PRODUCT DESCRIPTION

S. Himmelstein and Company offers three basic types of reaction torquemeters, i.e. Hollow Torquemeters, Shaft Torquemeters and Flanged Torquemeters. All use temperature compensated full foil gage torque bridge sensors that provide inherent cancellation of bending and thrust signals. The RTM hollow reaction series utilizes a patented (No. 3,800,591) double wall construction (except Model 2050) that economically provides unusual isolation and high torsional stiffness in a compact mechanical package. This is done without the use of multiple bridges, which have reduced reliability because of the increased number of bridge connections and wiring complexities.

With two exceptions, (see tabulation) all transducers are constructed of 15-5 PH, a precipitation hardened stainless steel with exceptional fatigue properties. In that connection, transducers subjected to full scale reversals have essentially infinite fatigue life. All models are furnished with a mating connector and precision shunt calibration resistor referenced to an NIST traceable dead weight calibration.

GENERAL SPECIFICATIONS

- Bridge Impedance:** 350 Ohms, nominal except Models 2050 thru 2070 which are 700 Ohms
- Nominal Output:** 1½ mV/V except Model 2137 and Models 2010 thru 2050 which are 1 mV/V
- Nonlinearity:** ±0.1% of full scale
- Nonrepeatability:** ±0.05% of full scale
- Hysteresis:** ±0.1% of full scale except Models 2010 thru 2070 and Model 1810(1-1) which are ±0.25% of full scale
- Torque Overload Capacity:** 2 times full scale rating
- Temperature Effects:** Zero = ±0.002% of full scale per degree F
Span = ±0.002% of reading per degree F
- Compensated Temperature Range:** +75 to +175 degrees F
- Usable Temperature Range:** -65 to +225 degrees F
- Maximum Excitation:** 10V (ac or dc) except 8V for Model 1810